

RANGE COMPOSITION

Zanussi Professional Self Service, a modern, versatile and elegant range of modular units for large catering outlets, capable of solving the problems associated with the distribution of meals.

The careful choice of materials and components and the design solutions adopted, guarantee a product that is the best of its kind for strength and reliability.

The range of heated plate lowerators consists of 2 models, 1 model, without castors, for plates with a maximum diameter of 255 mm and 1 model, with castors, for plates with a maximum diameter of 310 mm, both supplied with covers.



CMS + accessories

SELF SERVICE

HEATED PLATE LOWERATORS **ZANUSSI** PROFESSIONAL

FUNCTIONAL AND CONSTRUCTION FEATURES

◆ Constructed entirely in 304 AISI stainless steel.

◆ Plate lowerators suitable for the warming, transport and distribution of plates.

◆ Two cylinder plate lowerators, each cylinder can hold 50 plates with a diameter from 200 to 255 mm (Model CMS) and from 260 to 310 mm (Model CS3).

◆ Model CMS can be equipped with a set of special castors or feet and tray slides.

◆ Model CS3 is supplied with 4 castors, two with brakes, 125 mm in diameter.

◆ The sprung cylinders allow plates of different weights to be stacked.

◆ These units are insulated with glass wool.

◆ Model CMS suites in directly with the Fit Self-Service System, however on the Deco Self-Service System and the Techno Self-Service System both models of plate lowerator, CMS and CS3, need to be placed behind front units to maintain the look of the line.

◆ Plastic handles, one on Model CMS and two on Model CS3.

◆ All models comply with the standards required by the main international approval bodies and are CE marked.

TECHNICAL DATA		
CHARACTERISTICS	MODELS	
	CMS 320903	CS3 320910
Hot	I	I
External dimensions - mm		
width	375	460
depth	675	810
height	900	900
Worktop thickness - mm	50	50
Cabinet		
temperature - °C	60-80	60-80
Power - kW		
installed-electric	1.6	1.6
Supply voltage	220/240 V, 1+N, 50/60	220/240 V, 1+N, 50/60
Net weight - kg.	51	55
Capacity - n.		
plates	50	

320903

320910

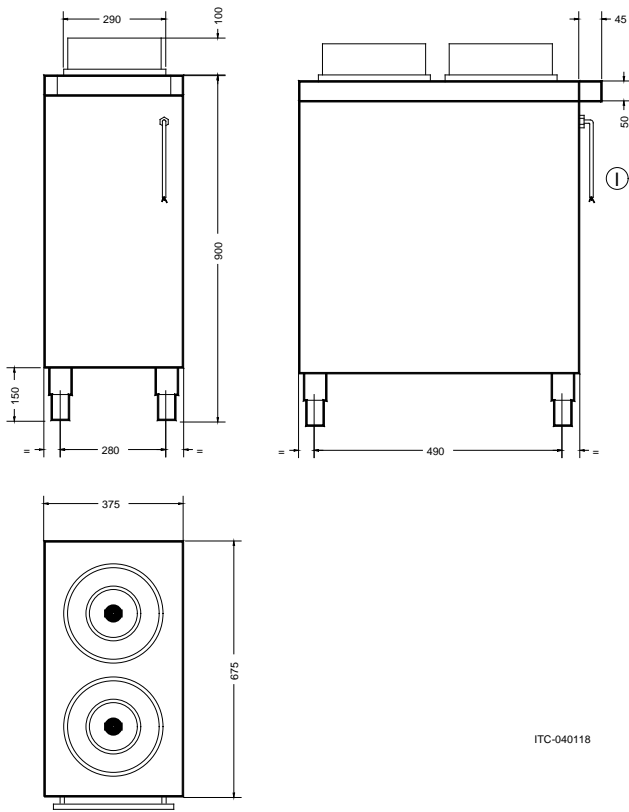

ITC-040118

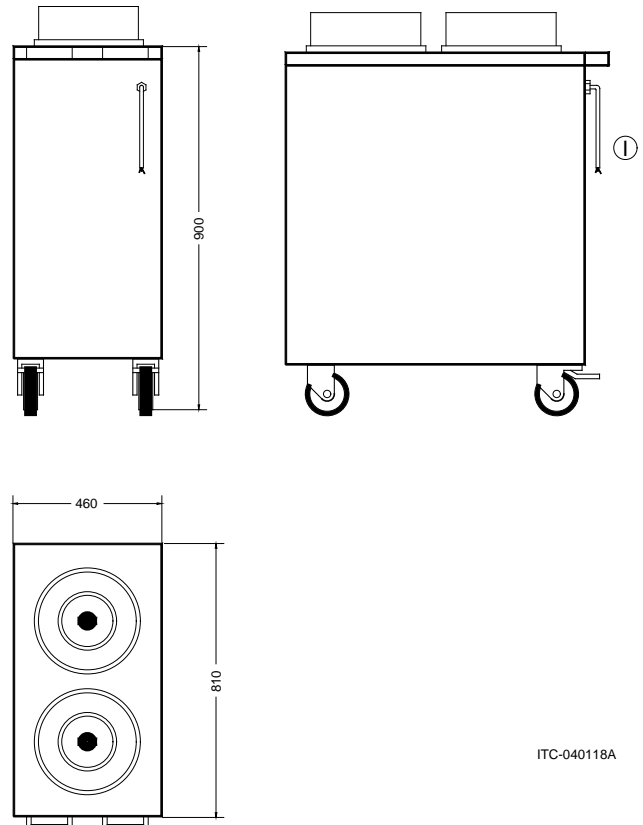

ITC-040118A



LEGEND

	CMS 320903	CS3 320910
I - Electrical connection	220/240 V, 1+N, 50/60	220/240 V, 1+N, 50/60

OPTIONAL ACCESSORIES

ACCESSORIES	MODELS	
	CMS 320903	CS3 320910
4 ADJUSTABLE FEET	852001	
TUBULAR TRAY SLIDE-375 MM	851030	



www.zanussiprofessional.com